

RYOBI®

OPERATOR'S MANUAL 10 in. (254 mm) DRILL PRESS MODEL DP101

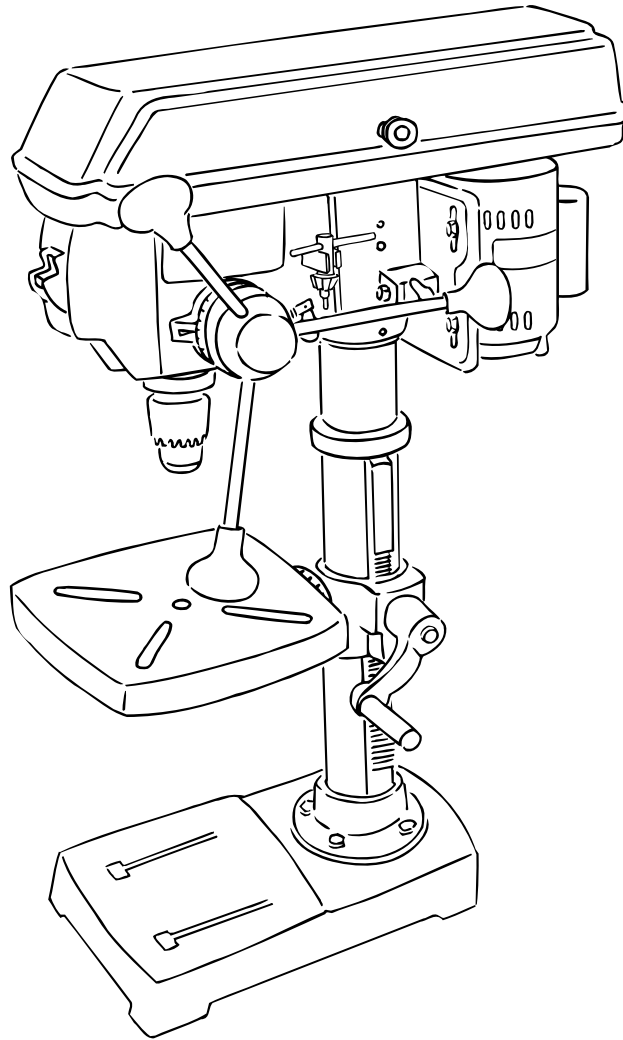

THANK YOU FOR BUYING A RYOBI BENCH TOP DRILL PRESS.

Your new Drill Press has been engineered and manufactured to Ryobi's high standards for dependability, ease of operation, and operator safety. Properly cared for, it will give you years of rugged, trouble-free performance.



CAUTION: Carefully read through this entire operator's manual before using your new machine.

Pay close attention to the Rules for Safe Operation, Warnings, and Cautions. If you use your machine properly and only for what it is intended, you will enjoy years of safe, reliable service.

Please fill out and return the Warranty Registration Card so we can be of future service to you.

Thank you again for buying Ryobi tools.

SAVE THIS MANUAL FOR FUTURE REFERENCE

TABLE OF CONTENTS

Rules for Safe Operation	3
Specific Safety Rules for Drill Presses	5
Electrical	6
Glossary of Terms	7
Features	8
Unpacking	9
Loose Parts List	9
Assembly	10-11
Tools Needed	10
Adjustments	11-12
Table Adjustments	11
Depth Stop Adjustment	12
Changing Speeds	12
Operation	13-14
General Information	13
On/Off Switch Key	13
Self-Ejecting Chuck Key	13
Operating Your Drill Press	13
Drilling Tips	14
Maintenance	14
General Maintenance	14
Lubricating	14
Troubleshooting	15
Parts Ordering / Service	16

PRODUCT SPECIFICATIONS

Chuck	1/2 in. (13 mm)	Input	120V AC, 60Hz, 3 amps
Taper	JT33/B16	Motor	1/4 HP Induction
No Load Speed	570 - 3050 RPM	Height	29 in. (718 mm)
Swing	10 in. (254 mm)	Net Weight	64 lbs (29 kg)
Spindle Travel	2-1/2 in. (60 mm)		



Look for this symbol to point out important safety precautions. It means attention!!! Your safety is involved.

⚠ WARNING:



The operation of any drill press can result in foreign objects being thrown into your eyes, which can result in severe eye damage. Before beginning power tool operation, always wear safety goggles or safety glasses with side shields and a full face shield when needed. We recommend Wide Vision Safety Mask for use over eyeglasses or standard safety glasses with side shields.

RULES FOR SAFE OPERATION

The purpose of safety symbols is to attract your attention to possible dangers. The safety symbols, and the explanations with them, deserve your careful attention and understanding. The safety warnings do not by themselves eliminate any danger. The instructions or warnings they give are not substitutes for proper accident prevention measures.

SYMBOL	MEANING
	SAFETY ALERT SYMBOL: Indicates danger, warning, or caution. May be used in conjunction with other symbols or pictographs.
	DANGER: Failure to obey a safety warning will result in serious injury to yourself or to others. Always follow the safety precautions to reduce the risk of fire, electric shock and personal injury.
	WARNING: Failure to obey a safety warning can result in serious injury to yourself or to others. Always follow the safety precautions to reduce the risk of fire, electric shock and personal injury.
	CAUTION: Failure to obey a safety warning may result in property damage or personal injury to yourself or to others. Always follow the safety precautions to reduce the risk of fire, electric shock and personal injury.
NOTE:	Advises you of information or instructions vital to the operation or maintenance of the equipment.

**SAFETY ALERT SYMBOL:**

Indicates danger, warning, or caution. May be used in conjunction with other symbols or pictographs.



DANGER: Failure to obey a safety warning will result in serious injury to yourself or to others. Always follow the safety precautions to reduce the risk of fire, electric shock and personal injury.



WARNING: Failure to obey a safety warning can result in serious injury to yourself or to others. Always follow the safety precautions to reduce the risk of fire, electric shock and personal injury.



CAUTION: Failure to obey a safety warning may result in property damage or personal injury to yourself or to others. Always follow the safety precautions to reduce the risk of fire, electric shock and personal injury.

NOTE:

Advises you of information or instructions vital to the operation or maintenance of the equipment.

IMPORTANT

Servicing requires extreme care and knowledge and should be performed only by a qualified service technician. For service we suggest you return the tool to your nearest **RYOBI AUTHORIZED SERVICE CENTER** for repair. When servicing, use only identical Ryobi replacement parts.

 WARNING:

Observe all normal safety precautions related to avoiding electrical shock.

** WARNING:**

Do not attempt to operate this tool until you have read thoroughly and understand completely all instructions, safety rules, etc. contained in this manual. Failure to comply can result in accidents involving fire, electric shock, or serious personal injury. Save this operator's manual and review frequently for continuing safe operation and instructing others who may use this tool.

RULES FOR SAFE OPERATION

READ AND UNDERSTAND ALL INSTRUCTIONS

1. **KNOW YOUR POWER TOOL.** Safe operation of this power tool requires that you read and understand this operator's manual and all labels affixed to the tool. Learn its applications and limitations as well as the potential hazards.

WARNING:

Do not connect your drill press to a power source until you have assembled and adjusted the drill press as described in this manual and have read and understood all precautions and operating instructions in the manual and printed on the tool.

WARNING:

When using electric tools, basic safety precautions should always be followed to reduce the risk of fire, electric shock, and personal injury. Use common sense. Some of these basic safety precautions include the following:

SAFETY PRECAUTIONS

2. **KEEP GUARDS IN PLACE** and in good working order.
3. **REMOVE ADJUSTING KEYS AND WRENCHES.** Get in the habit of checking to see that hex keys and adjusting wrenches are removed from the tool before turning it on.
4. **KEEP THE WORK AREA CLEAN.** Cluttered work areas and work benches invite accidents.
5. **DO NOT USE IN DANGEROUS ENVIRONMENTS.** Do not use power tools near gasoline or other flammable liquids, in damp or wet locations, or expose them to rain. Keep the work area well lighted.
6. **KEEP CHILDREN AWAY FROM POWER TOOLS.** All visitors should be kept at a safe distance from the work area.
7. **MAKE THE WORKSHOP CHILD-PROOF** with padlocks and master switches or by removing starter keys.
8. **DO NOT FORCE THE TOOL.** It will do the job better and safer at the rate for which it was designed.
9. **USE THE RIGHT TOOL.** Do not force the tool or attachment to do a job for which it was not designed.
10. **USE PROPER EXTENSION CORD.** Make sure your extension cord is in good condition. When using an extension cord, be sure to use one heavy enough to carry the current your product will draw. A wire gage size (A.W.G.) of at least **16** is recommended for an extension cord 100' or less in length. A cord exceeding 100' is not recommended.
11. **WEAR PROPER APPAREL.** Do not wear loose clothing, gloves, neckties, rings, bracelets, or other jewelry that could get caught in moving parts. Non-slip footwear is recommended. Wear protective covering over long hair.
12. **ALWAYS WEAR SAFETY GLASSES WITH SIDE SHIELDS.** Everyday eyeglasses have only impact resistant lenses; they are **not** safety glasses.
13. **PROTECT YOUR LUNGS.** Wear a face or dust mask if the drilling operation is dusty.
14. **PROTECT YOUR HEARING.** Wear hearing protection during extended periods of operation.
15. **SECURE THE WORK.** Use clamps or a vise to hold the work when practical. It's safer than using your hand and frees both hands to operate the tool.
16. **DO NOT OVERREACH.** Keep proper footing and balance at all times.
17. **MAINTAIN THE TOOL WITH CARE.** Keep bits sharp and clean for the best and safest performance. Follow instructions for lubricating and changing accessories.
18. **DISCONNECT POWER TOOLS BEFORE SERVICING** or before changing accessories such as blades, bits and cutters.
19. **REDUCE THE RISK OF UNINTENTIONAL STARTING.** Make sure switch is in the OFF position before plugging in the tool.
20. **USE ONLY ACCESSORIES RECOMMENDED BY THE MANUFACTURER.** Consult this operator's manual for recommended accessories. Using improper accessories may cause risk of injury.
21. **NEVER STAND ON TOOL.** Serious injury could occur if the tool is tipped or if the bit is unintentionally contacted.
22. **PERIODICALLY CHECK FOR WORN OR DAMAGED PARTS.** Check for alignment of moving parts, binding of moving parts, breakage of parts, loose mounting brackets, and any other conditions that may affect operation. A guard or any other part that is damaged should be properly repaired or replaced. Before the tool is used again, make sure that the repaired or replaced part is operating properly and performing its intended function.
23. **NEVER LEAVE TOOL RUNNING UNATTENDED.** Turn the power off. Do not leave tool until it comes to a complete stop.
24. **DO NOT ABUSE CORD.** Never yank the cord to disconnect it from the receptacle. Keep the cord from heat, oil, and sharp edges.
25. **KEEP BITS CLEAN AND SHARP.** Sharp bits minimize stalling. Dirty and dull bits may cause misalignment of the material and possible operator injury.
26. **KEEP HANDS AWAY FROM WORK AREA.** Keep hands away from the bit. Restrain any loose clothing, jewelry, long hair, etc. that may become entangled in the bit.
27. **KEEP TOOL DRY, CLEAN, AND FREE FROM OIL AND GREASE.** Always use a clean cloth when cleaning. Never use brake fluids, gasoline, petroleum-based products, or any solvents to clean tool.
28. **STAY ALERT.** Never operate a power tool when tired or while under the influence of drugs, alcohol or medication.

RULES FOR SAFE OPERATION

29. **DO NOT USE TOOL IF SWITCH DOES NOT TURN IT ON AND OFF.** Have defective switches replaced by an authorized service center.
30. **ALWAYS TURN SWITCH OFF** before disconnecting it to avoid accidental starting.
31. **ALL REPAIRS, WHETHER ELECTRICAL OR MECHANICAL,** should be made at a Ryobi Authorized Service Center. Use only Ryobi identical replacement parts.
32. **SAVE THESE INSTRUCTIONS.** Refer to them frequently and use to instruct other users. If you loan someone this tool, loan them these instructions also.

WARNING:

Some dust created by power sanding, sawing, grinding, drilling, and other construction activities contains chemicals known to cause cancer, birth defects or other reproductive harm. Some examples of these chemicals are:

- lead from lead-based paints,
- crystalline silica from bricks and cement and other masonry products, and
- arsenic and chromium from chemically-treated lumber.

Your risk from these exposures varies, depending on how often you do this type of work. To reduce your exposure to these chemicals: work in a well ventilated area, and work with approved safety equipment, such as those dust masks that are specially designed to filter out microscopic particles.

SPECIFIC SAFETY RULES FOR DRILL PRESSES

1. Always wear eye protection.
2. Always disconnect the tool from the power source when setting up, adjusting, or changing accessories.
3. Do not wear gloves necktie, or loose clothing.
4. Always clamp workpiece and brace against column to prevent rotation.
5. Use recommended speed for drill accessory and workpiece material.
6. Be sure drill bit or cutting tool is securely locked in the chuck.
7. Be sure chuck key is removed from the chuck before connecting to power source or turning power **ON**.
8. Adjust the table or depth stop to avoid drilling into the table. Shut off the power, remove the drill bit, and clean the table before leaving machine.
9. Do not connect tool to power source or operate until it is completely assembled and installed according to the instructions. If any part of your drill press malfunctions or has been damaged or broken, do not operate until the part is properly repaired or replaced.
10. Never place your fingers in a position where they could contact the drill or other cutting tool if the workpiece should unexpectedly shift.
11. Never use your hand to hold the object while drilling. Always clamp the object tight on the work table or use a drill vise to prevent accidental injury.
12. Never perform any operation by moving the head or table with respect to one another. Do not turn the motor switch **ON** or start any operation before checking that the head and table lock handles are clamped tight to column and head and table support collars are correctly positioned.
13. Before engaging the power switch **ON**, make sure the belt guard is down and the chuck is installed properly.
14. Lock the motor switch **OFF** when leaving the drill press. Do not perform layout, assembly, or set-up work on the table while the cutting tool is rotating, switched on or connected to a power source.
15. Firmly clamp or bolt your drill press to a work bench or table.
16. **SAVE THESE INSTRUCTIONS.** Refer to them frequently and use to instruct other users. If you loan someone this tool, loan them these instructions also.

ELECTRICAL

GROUNDING INSTRUCTIONS

In the event of a malfunction or breakdown, grounding provides a path of least resistance for electric current to reduce the risk of electric shock. This tool is equipped with an electric cord having an equipment-grounding conductor and a grounding plug. The plug must be plugged into a matching outlet that is properly installed and grounded in accordance with all local codes and ordinances.

Do not modify the plug provided. If it will not fit the outlet, have the proper outlet installed by a qualified electrician. Improper connection of the equipment-grounding conductor can result in electrical shock. The conductor with the insulation having an outer surface that is green with or without yellow stripes is the equipment-grounding conductor. If repair or replacement of the electric cord or plug is necessary, do not connect the equipment-grounding conductor to a live terminal.

Check with a qualified electrician or service personnel if the grounding instructions are not completely understood, or if in doubt as to whether the tool is properly grounded.

Repair or replace a damaged or worn cord immediately.

This tool is intended for use on a circuit that has an outlet like the one shown in Figure 1. It also has a grounding pin like the one shown.

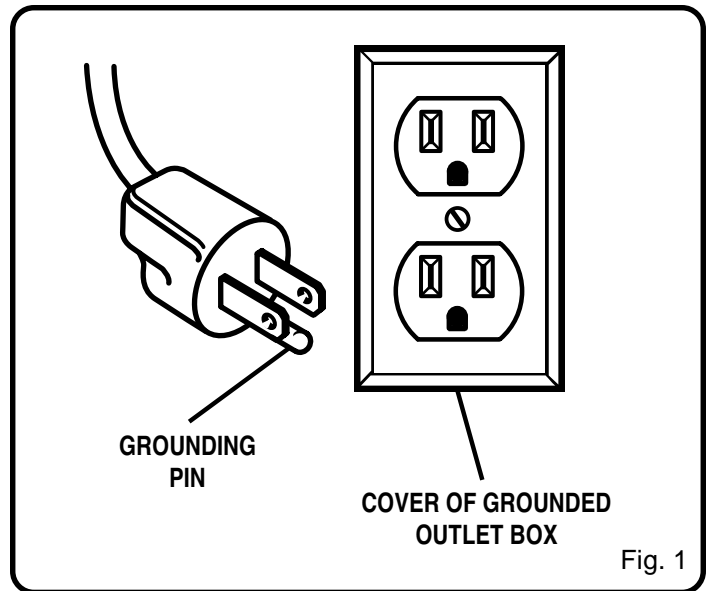

Fig. 1

GLOSSARY OF TERMS

Base

Large rectangular plate that secures the drill press to a benchtop or other sturdy, level surface.

Chip

The material extracted from the hole in a drilling operation.

Chuck

The clamping device at the end of the spindle that secures the drill bit.

Chuck Key

A fitted key used to tighten and loosen the chuck.

Column

Large perpendicular rod that supports the work table and drill press head assembly.

Depth Stop

Adjustment control which allows the operator to control the depth of the hole in a drilling operation.

Drill Bit

Fluted cutting tool used in a drilling operation.

Drill Press Head

The assembly at the top of the column which houses the motor, quill, and spindle.

Feed

The speed and force with which the drill bit is lowered into the workpiece.

Feed Handles

Three handles attached to the quill which allow the operator to lower the chuck and bit during a drilling operation.

Motor Pulley

A grooved, conical pulley driven by the motor and responsible for driving the spindle pulley by means of a belt.

Pilot Hole

A small hole drilled in a workpiece that serves as a guide for drilling large holes accurately.

Quill

Also known as the Feed Shaft. Responsible for lowering the chuck and bit into the workpiece and regulating the depth of the hole in a drilling operation.

Spindle

The rotating shaft upon which the chuck is attached.

Spindle Pulley

A grooved, conical pulley responsible for rotating the spindle. The spindle pulley is driven by the motor pulley by means of a belt.

Workpiece

The object into which a hole is to be drilled.

Work Table

Flat, level surface supported on the column and able to be positioned at various angles vertically on the column in order to accommodate different size workpieces.

FEATURES

KNOW YOUR DRILL PRESS

Familiarize yourself with the following features of your benchtop drill press before connecting it to a power source and using it.

Motor

Equipped with an industrial duty, 1/4 HP induction motor for long lasting, smooth performance.

Spindle Speeds

5 spindle speeds allow you to drill a wide variety of material from wood to plastic to metal.

Drill Chuck

Standard 3-jaw type with a self-ejecting chuck key included.

Self-Ejecting Chuck Key

Key automatically ejects from the chuck to prevent accidentally starting drill press with key still engaged in chuck.

Spindle

Spindle is supported by quality ball bearings to ensure accuracy.

Depth Stop

Adjustable locking depth stop for accurate depth measurement and repetitive drilling.

Chuck Key Storage

On-board chuck key storage keeps key within easy reach.

Worktable

Rotating, tilting, crank operated work table for added versatility. Slotted worktable and base allows easy application of clamping devices.

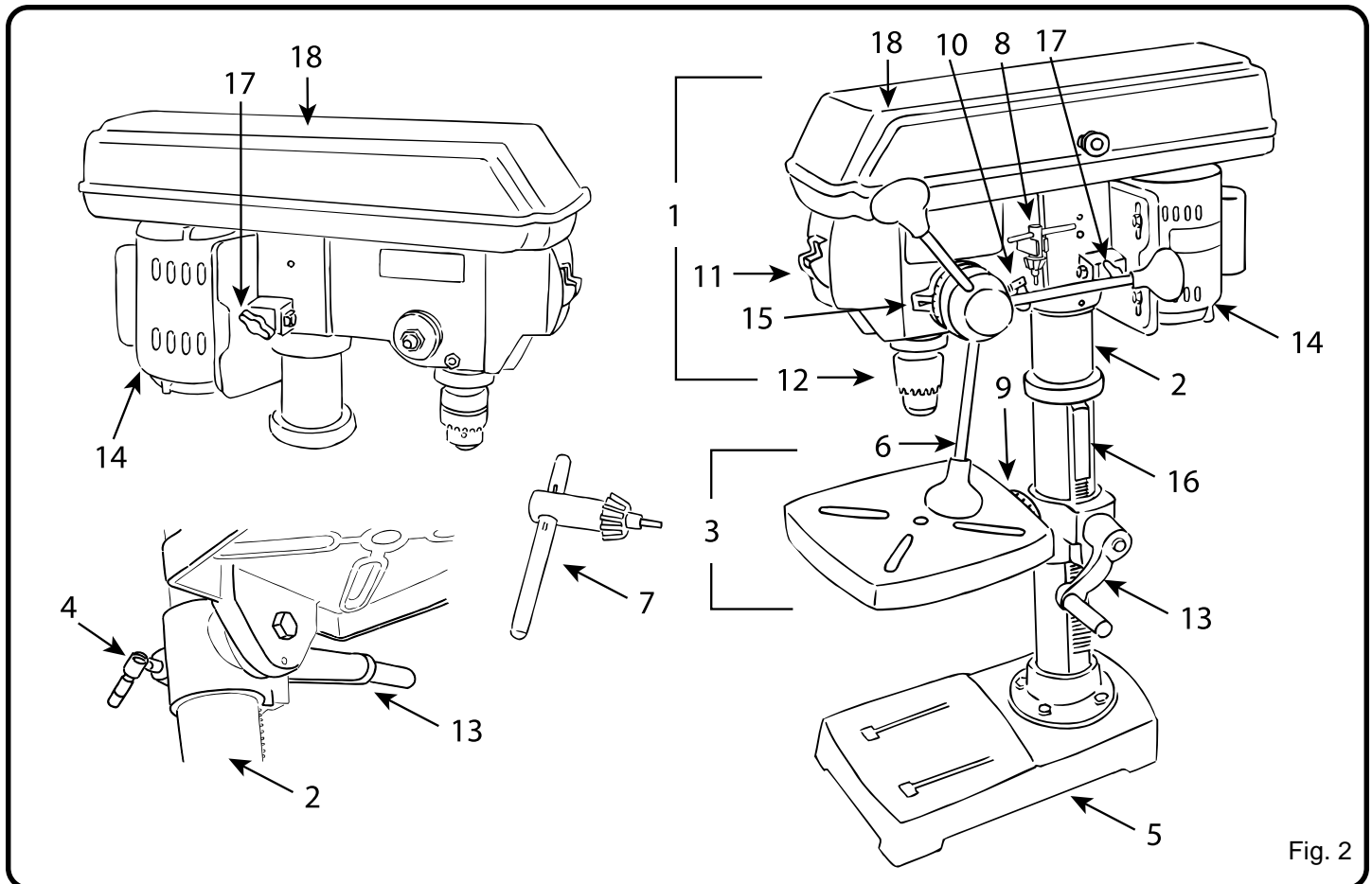

Fig. 2

- | | |
|------------------------------|------------------------|
| 1. Drill Press Head Assembly | 10. Depth Stop |
| 2. Column | 11. On/Off Switch |
| 3. Table Assembly | 12. Chuck |
| 4. Table Lock Handle | 13. Table Crank Handle |
| 5. Base | 14. Motor |
| 6. Feed Handles | 15. Depth Scale |
| 7. Chuck Key | 16. Gear Rack |
| 8. Chuck Key Storage | 17. Belt Tension Knobs |
| 9. Bevel Scale | 18. Pulley Housing |

UNPACKING

1. Carefully remove all parts from the shipping carton.
2. Do not discard the packing material until you have identified all the parts in the parts list.
3. If all parts have been included, proceed to assembly.
4. If you are missing a part, contact your dealer to obtain it before attempting to assemble the tool.
5. Examine all the parts to make sure no breakage has occurred during shipping. Any damaged or missing part should be replaced before attempting to use the tool.

⚠ WARNING:

Do not allow familiarity with your drill press to make you careless. Remember that a careless fraction of a second is sufficient to inflict severe injury.

⚠ WARNING:

Do not attempt to assemble the drill press, plug in the power cord, or turn on switch if any parts are damaged or missing. Failure to heed this warning could result in serious personal injury.

LOOSE PARTS

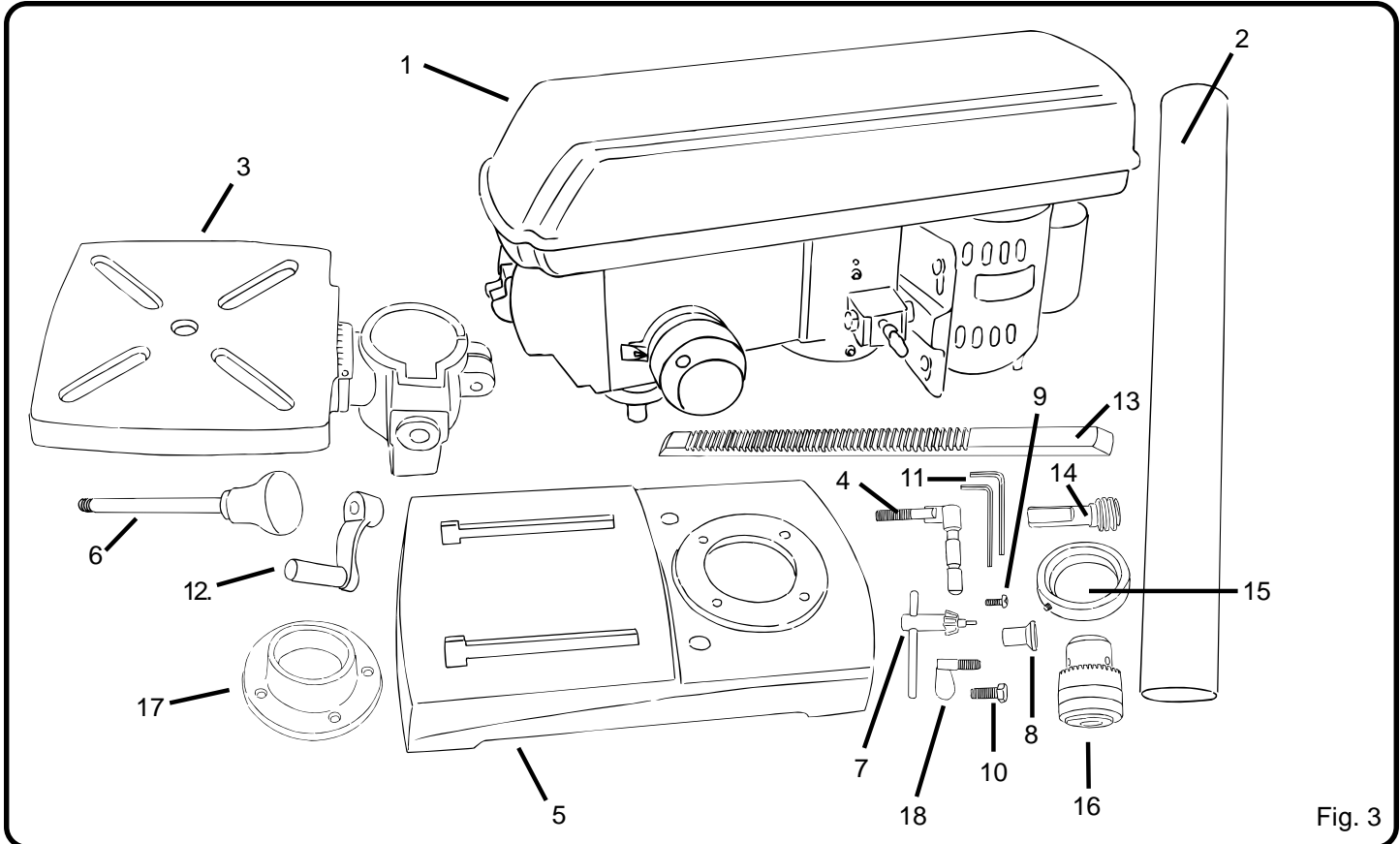

Fig. 3

- | | |
|---------------------------|-----------------------------------|
| 1. Head Assembly | 11. Hex Wrench |
| 2. Column | 12. Table Crank Handle |
| 3. Table Assembly | 13. Gear Rack |
| 4. Table Lock Handle | 14. Worm Gear |
| 5. Base | 15. Column Collar |
| 6. Feed Handles (3) | 16. Chuck |
| 7. Chuck Key | 17. Base Collar |
| 8. Pulley Housing Knob | 18. Scale Set Handle |
| 9. M5 Pan Head Screw | 19. Operator's Manual (not shown) |
| 10. M8 1.25 Hex Bolts (4) | |

ASSEMBLY

TOOLS NEEDED FOR ASSEMBLY

#1 and #2 Philips Screwdriver
Adjustable Wrench
Hammer or rubber mallet

1. Place the base on a flat surface and assemble the column to the base using the four M8 hex bolts.
2. Locate the worm gear and feed the D-shaft through the hole in the table assembly as shown in Figure 4.

Insert the D-shaft through the hole in the table crank. Align flat side of shaft with the set screw on the table crank handle. Tighten set screw using the 4 mm hex wrench.

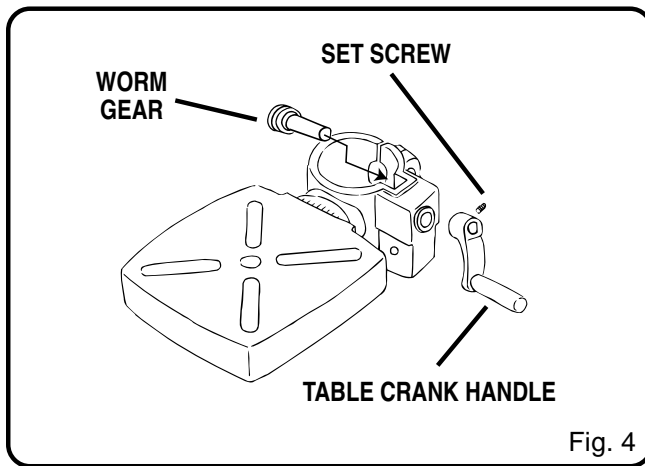

3. Feed the gear rack through the slot in the table assembly so that the teeth are facing out and the longer smooth end faces up. The worm gear should engage the gear rack.

Using both hands, slide the entire assembly onto the column until the bottom of the gear rack is positioned against the base collar. See Figure 5.

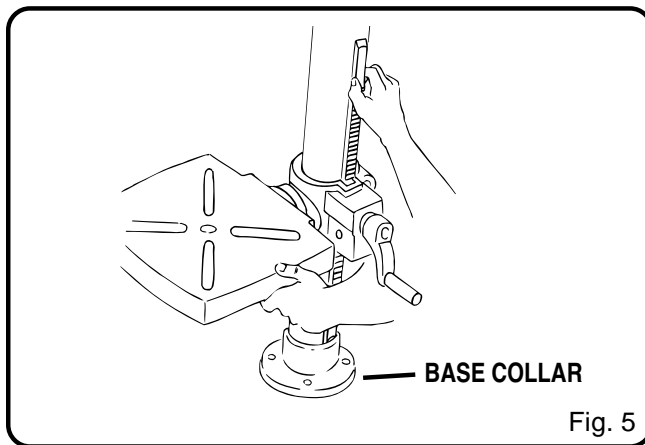

4. Slide the column collar, bevel side down, over the column until the beveled side engages the beveled end of the gear rack. Tighten the set screw in the collar using the 4 mm hex wrench. See Figure 6. Do not overtighten.

NOTE: Table should be able to move side to side. Do not overtighten set screw.

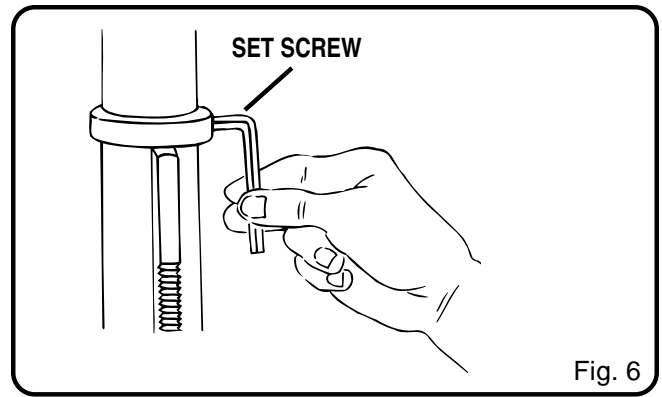

5. Locate the table lock handle. Insert it into the threaded hole at the rear of the table assembly and tighten by hand.
6. Position head assembly upside down on a level, flat surface. Position chuck on spindle. Chuck should be fully opened to avoid damaging jaws. Using a piece of scrap wood to protect the chuck, firmly tap the chuck into place using a hammer.

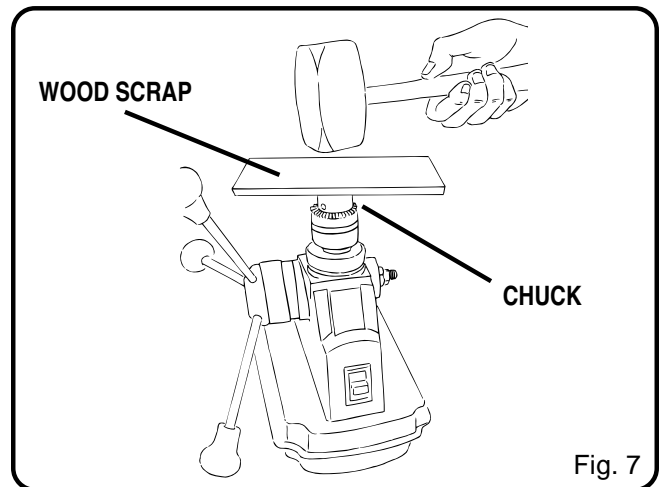

7. Lift head assembly onto column with the spindle positioned over the table. Slide head assembly down as far as it will go. Tighten the two head set screws with the 4 mm hex wrench. See Figure 8.

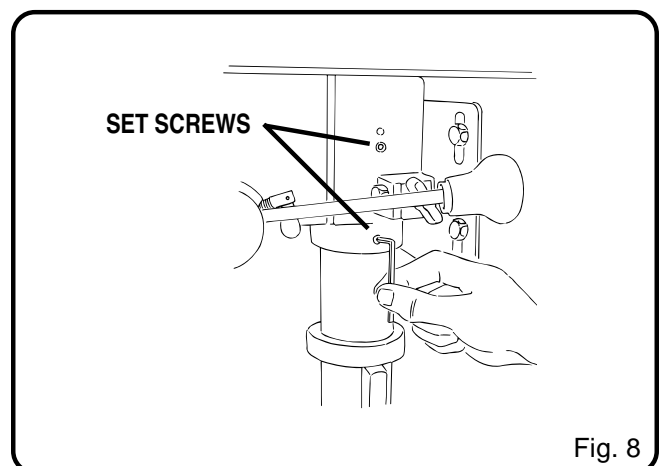

ASSEMBLY

- Attach the three feed handles by screwing them into the threaded holes in the hub.
- Using the pre-drilled holes in the base, mount your drill press securely on a sturdy surface such as a work stand, workbench or counter top. *See Figure 9.* If your drill press is to be used in a portable application, it is recommended that you fasten it permanently to a mounting board that can be easily clamped to a workbench.

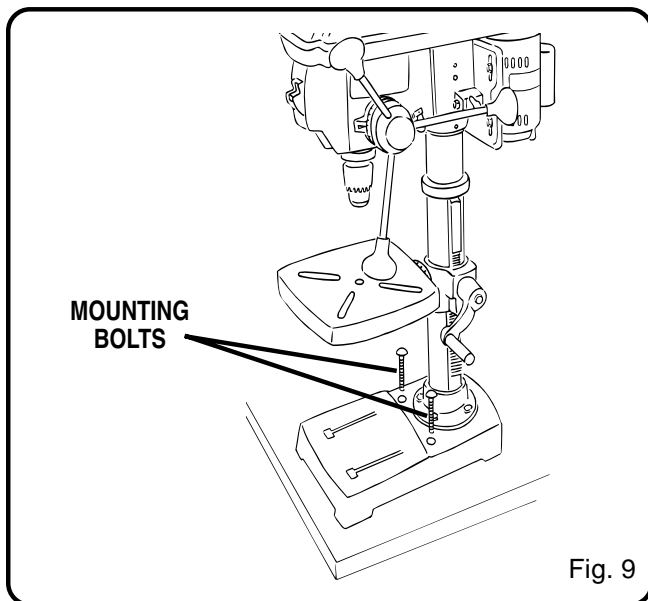

⚠ WARNING:

Do not connect to power supply until assembly is complete. Failure to comply could result in accidental starting and possible serious injury.

Once securely mounted on a sturdy surface, check the following:

- Check for vibration when the motor is switched **ON**. Adjust and retighten the mounting hardware as necessary.
- Check the table assembly to assure smooth movement up and down the column.
- Check to assure that the spindle shaft moves smoothly.

ADJUSTMENTS

⚠ WARNING:

Before adjustment, disconnect the drill press from the power source.

TABLE ADJUSTMENTS

Adjusting the Table Height

See Figure 10.

To adjust table, hold the table with one hand and loosen the table lock handle. Rotate the table crank handle to lower or raise the table. Clockwise raises the table; counterclockwise lowers it. Position the table in the desired position and retighten the lock handle.

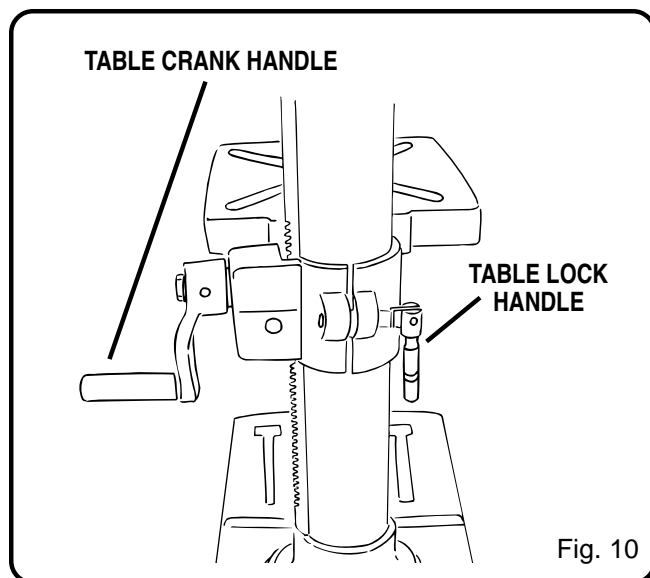

ADJUSTMENTS

Bevel Adjustment

See Figures 11 and 12.

Your drill press is equipped with a tilting table that allows you to drill angled holes. The table can be tilted left or right, from 0-45 degrees.

To tilt the table, loosen the large hex bolt located underneath the table. Use the bevel scale to tilt table to the desired angle, then tighten hex bolt.

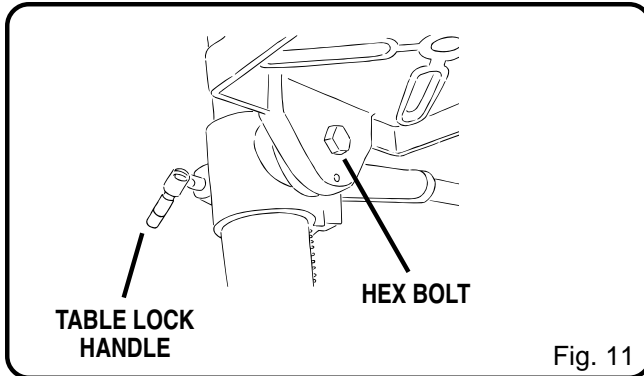

Fig. 11

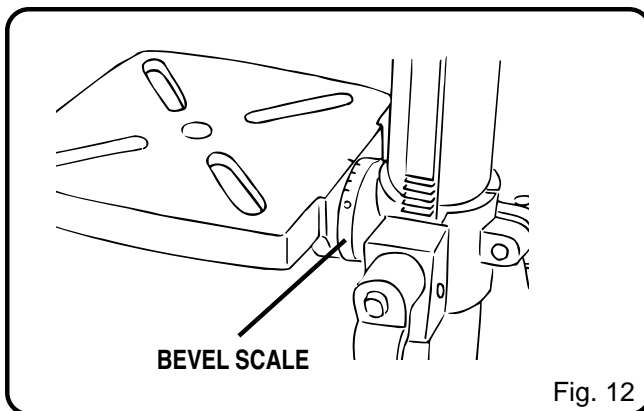

Fig. 12

Table Rotation

See Figure 11.

When drilling large objects it may be necessary to swing the table out of the way. Simply loosen the table lock lever, rotate table, and retighten table lock lever.

Note: When using the base as a work surface, the workpiece must be clamped securely to the base.

DEPTH STOP ADJUSTMENT

See Figure 13.

Where a number of holes are to be drilled to exactly the same depth, the depth stop is used as follows.

Loosen scale set handle located on the feed shaft assembly and rotate feed handle to desired spindle depth. Rotate depth scale counterclockwise to positive stop. Retighten scale set handle securely.

To set at a stationary depth, loosen scale set handle and rotate feed handle to desired spindle depth. Rotate depth scale clockwise to positive stop. Retighten scale set handle securely. This will hold the spindle assembly stationary at desired depth.

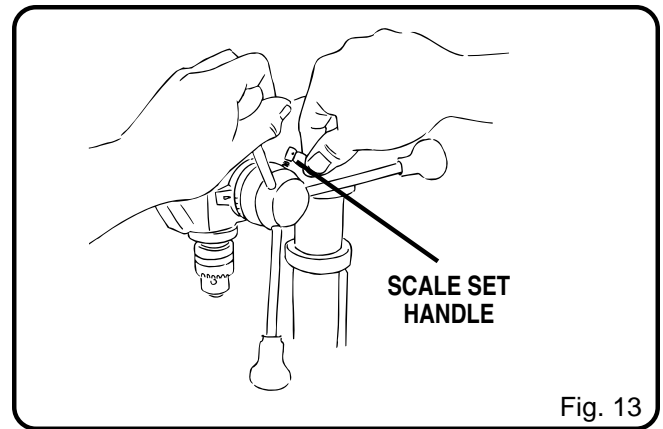

Fig. 13

CHANGING SPEEDS

See Figure 14.

The spindle speed is determined by the location of the belt on the pulleys in the pulley housing. The reference chart located inside the pulley housing shows the recommended speed and pulley configuration for each drilling operation. To change the pulley configuration, refer to Figure 14 and proceed as follows:

Loosen the two belt tension knobs located on either side of the head assembly. See Figure 2.

Push the motor assembly toward the front of the head assembly to loosen the drive belt.

Open the pulley housing cover and reposition the belt according to the speed chart. Close the housing cover.

Push motor firmly back to position assuring drive belt is tight. While holding tension on motor, retighten the two belt tension knobs securely. See Figure 2.

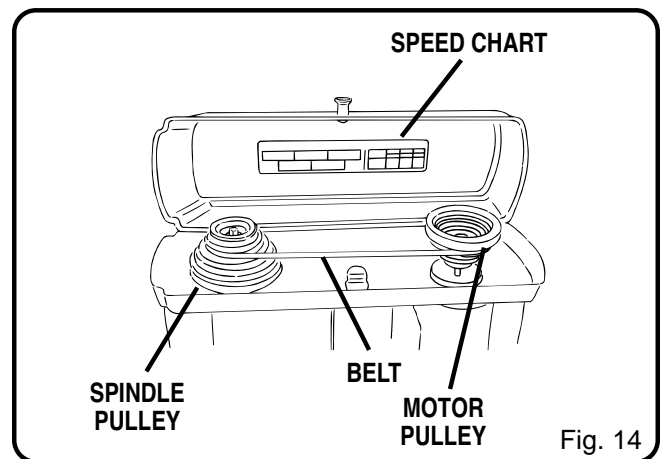

Fig. 14

OPERATION

GENERAL INFORMATION

⚠ WARNING:

Before performing any adjustment, make sure the drill press is unplugged from the power supply and the switch is in the **OFF** position. Failure to heed this warning could result in serious personal injury.

⚠ WARNING:

Your drill press has a precision built electric motor. It should only be connected to a **power supply that is 120 volts, 60 Hz, AC only (normal household current)**. Do not operate this tool on direct current (DC). A substantial voltage drop will cause a loss of power and the motor will overheat. If your tool does not operate when plugged into an outlet, double check the power supply.

ON/OFF SWITCH KEY

Your drill press is equipped with an on/off switch key. When removed, the switch key prevents the drill press from being turned on. The key must be in place to turn the drill press on. If the key is removed during operation, the drill press can be turned off but may not be turned on again until the key is replaced.

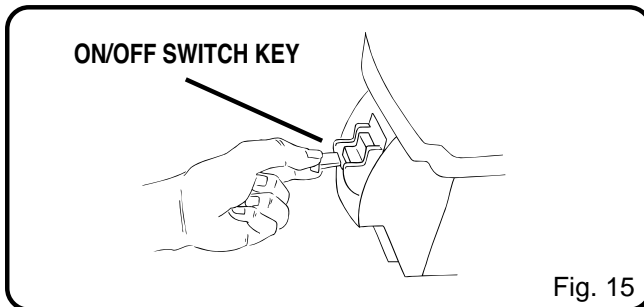

SELF-EJECTING CHUCK KEY

The self-ejecting chuck key ensures that the chuck key is removed from the chuck **BEFORE** the drill press is turned on.

In order to loosen or tighten the chuck using the chuck key, push the key into the chuck hole. You will feel the spring loaded key tighten. Rotate the key clockwise to tighten the chuck, counterclockwise to loosen the chuck. When you are finished with the chuck key, always replace it in the on-board chuck key storage located on the drill press head assembly.

⚠ WARNING:

Use only the self-ejecting chuck key provided. Always remove chuck key and store in the on-board chuck key storage. Failure to heed this warning could result in serious personal injury.

⚠ WARNING:

Always remember to remove the chuck key from the table surface before turning on the drill press. Failure to heed this warning could result in serious personal injury.

⚠ WARNING:

Do not attempt to operate this tool until you have read thoroughly and understand completely all instructions, safety rules, etc. contained in this manual. Failure to comply can result in accidents involving fire, electric shock, or serious personal injury. Save this operator's manual and review it frequently for continuing safe operation and instructing others who may operate this tool.

⚠ WARNING:

Before attempting to use your drill press familiarize yourself with all operating features and safety requirements.

OPERATING YOUR DRILL PRESS

See Figures 16 and 17.

1. Using a C-clamp or similar clamping device, secure the workpiece to the work table. To protect the top surface of the workpiece, use a piece of scrap between the clamp and the workpiece.
2. Select the proper drill bit based on the hole size desired. For large holes, drill a pilot hole first, using a smaller diameter bit.

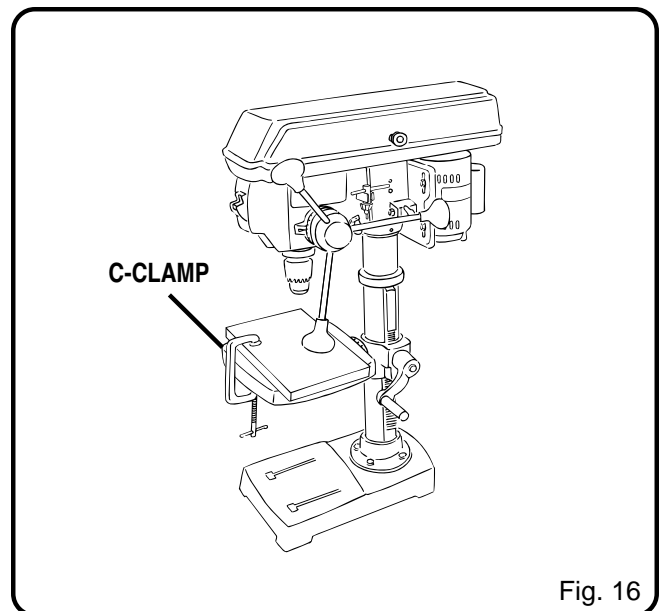

OPERATION

- Loosen the chuck by inserting the chuck key into the chuck and turning the chuck key counterclockwise. See Figure 17.
- Place drill bit between the jaws of the chuck and tighten chuck by turning the key clockwise.
- Set table assembly to desired height. See page 11. If desired, set quill at desired spindle depth. See Depth Stop Adjustment on page 12.

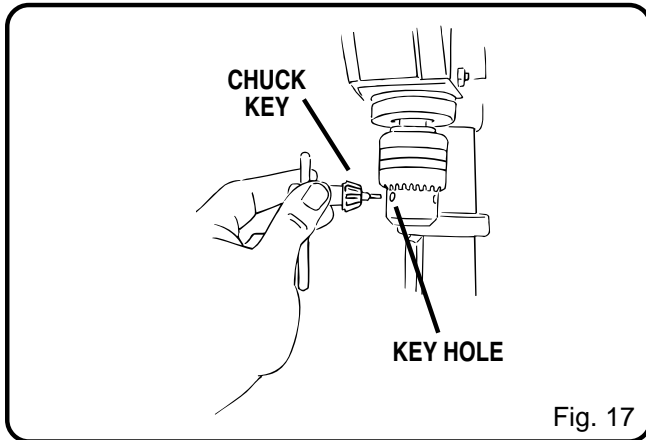

- Make sure the work table is free of all loose objects and that the bit is not in contact with the workpiece.
- Plug electrical cord into power supply and turn switch **ON**. Make sure spindle rotates freely.
- Slowly lower drill bit into workpiece. Do not force the bit, let the drill press do the work.
- Once the hole is completed, allow the spring-loaded quill to return to its normal position. This will automatically raise the chuck and bit.

DRILLING TIPS

If the hole is large, it's a good idea to drill a smaller pilot hole before drilling the final one. Your hole will be more accurately positioned, rounder, and the bits will last longer.

If the hole is deeper than it is wide, back off occasionally to clear the chips. When drilling metal also use a coolant.

As you increase the drill size, you may need to reduce the spindle speed.

If drilling a through hole, make sure that the bit will not drill into the table after moving through your work.

MAINTENANCE

⚠ WARNING:

When servicing use only identical Ryobi replacement parts. Use of any other parts may create a hazard or cause product damage.

⚠ WARNING:

To avoid serious personal injury make sure the drill press is turned **OFF** and the cord is unplugged from the power source before performing any maintenance or adjustment.

GENERAL MAINTENANCE

After using your drill press, clean it completely and lubricate all sliding and moving parts. Apply a light coat of automotive type paste wax to the table and column to help keep the surfaces clean.

Motor Housing

Frequently blow out any dust that may accumulate inside the motor housing.

Worm Gear and Gear Rack

Periodically lubricate the worm gear and gear rack in order to keep the vertical movement smooth and to help prolong the life of your drill press.

Pulleys

Should you feel an unusually high level of vibration, the pulleys may not be tightly secured on the motor and/or spindle shafts. To make sure the pulleys are properly seated and tight, locate the set screw on each of the pulleys as shown in Figure 18. Tighten each set screw with a 4 mm hex wrench.

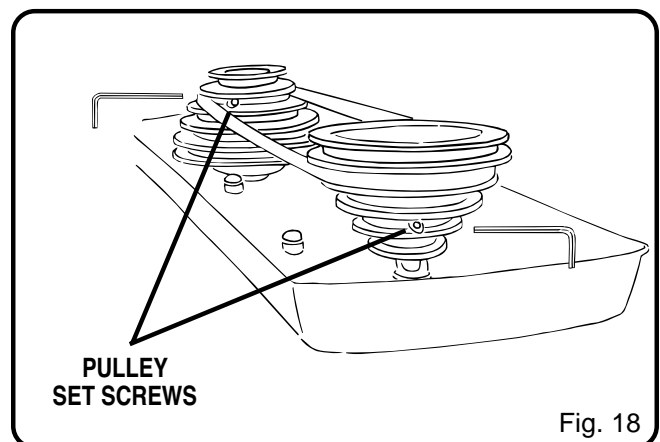

LUBRICATION

The ball bearings in the quill and V-belt pulley are permanently lubricated. To lubricate the spindle, pull quill down to maximum depth and oil moderately once every three months. Oil all slide bars lightly every two months. If cranking becomes difficult, grease bracket lightly.

TROUBLE SHOOTING

Problem	Possible Cause	Solution
Noisy operation.	Incorrect belt tension. Dry spindle. Loose spindle pulley or motor pulley.	Adjust belt tension. See page 12. Lubricate spindle. See page 14. Tighten set screws in pulleys. See page 14.
Bit burns or smokes.	Incorrect speed. Chips not coming out of hole. Dull bit. Feeding too slow. Not lubricated.	Change speed. See page 12. Retract bit frequently to clear chips. Sharpen or replace bit. Feed fast enough, allow drill to cut. Lubricate bit for metal work.
Excessive drill runout or wobble.	Bent bit. Bit not properly installed in chuck. Chuck not properly installed. Worn spindle bearings.	Replace bit. Install bit properly. See page 14. Install chuck properly. See page 10. Contact Ryobi Authorized Service Center.
Drill bit binds in workpiece	Excessive feed pressure. Improper belt tension.	Reduce feed pressure. Adjust belt tension. See page 12.
Workpiece support loosens	Workpiece not supported or clamped properly.	Check support and/or re-clamp workpiece. See page 13.



OPERATOR'S MANUAL

10 in. (254 mm) Drill Press

Model DP101

EXTENSION CORD CAUTION

When using a power tool at a considerable distance from a power source, be sure to use an extension cord that has the capacity to handle the current the tool will draw. An undersized cord will cause a drop in line voltage, resulting in overheating and loss of power. Use the chart to determine the minimum wire size required in an extension cord. Only round jacketed cords should be used.

When working with a tool outdoors, use an extension cord that is designed for outside use. This is indicated by the letters "WA" on the cord's jacket.

Before using any extension cord, inspect it for loose or exposed wires and cut or worn insulation.

**Ampere rating

(on tool data plate) 0-2.0 2.1-3.4 3.5-5.0 5.1-7.0 7.1-12.0 12.1-16.0

Cord Length	Wire Size (A.W.G.)					
	16	16	16	16	14	14
25'	16	16	16	16	14	14
50'	16	16	16	14	14	12
100'	16	16	14	12	10	—

CAUTION: Keep the extension cord clear of the working area. Position the cord so that it will not get caught on workpiece, tools, or other obstructions while you are working with a power tool.

***Used on 12 gauge - 20 amp circuit.*

• SERVICE

Now that you have purchased your tool, should a need ever exist for repair parts or service, simply contact your nearest Ryobi Authorized Service Center. Be sure to provide all pertinent facts when you call or visit. Please call 1-800-525-2579 for your nearest Ryobi Authorized Service Center. You can also check our web site at www.ryobitools.com for a complete list of Authorized Service Centers.

• MODEL NO.

The model and serial numbers of your tool will be found on the data plate attached to the head assembly. Please record the serial number in the space provided below.

- MODEL NUMBER DP101
- SERIAL NUMBER _____

RYOBI TECHNOLOGIES, INC.

1428 Pearman Dairy Road Anderson, SC 29625
 Post Office Box 1207 Anderson SC 29622-1207
 Phone 1-800-525-2579
www.ryobitools.com